



## VELOUR GLASS TABLE ASSEMBLY

### Base Part Location and Verification

Location	Quantity	Description	QC Check
Base Box	4	Legs	
Table Box	1	Frame Assembly	

### Hardware List and Verification

Quantity	Description	QC Check
8	2 1/2" Lag Bolts	
4	Rubber Bumpers	

QUALITY CONTROL CHECK PERFORMED BY: \_\_\_\_\_

**ATTENTION**  **Do Not Assemble with Power Tools**

### ASSEMBLY INSTRUCTIONS:

- 1) ATTACH THE LEGS TO THE FRAME ASSEMBLY; USE 8 – 2 1/2" LAG BOLTS (2 PER LEG).  
SEE *FIGURE 1*.
- 2) ATTACH RUBBER BUMPERS TO INSIDE CORNERS OF FRAME TO SUPPORT GLASS.  
SEE *FIGURE 2*.
- 3) CENTER GLASS ON TOP OF FRAME (**TEXTURED SIDE DOWN**) WITH SAME OVERHANG ON ALL 4 CORNERS.

*FIGURE 1*

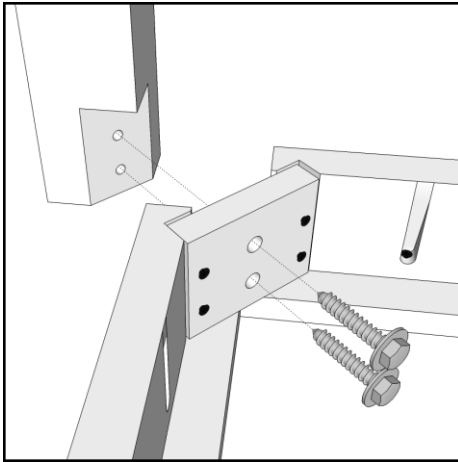

*FIGURE 2*

