



EXTENSION – CANAAN TABLE ASSEMBLY

Base Part Location and Verification

Location	Quantity	Description	QC Check
Base Box	2	Legs	
Base Box	1	Stretcher	

Hardware List and Verification

Quantity	Description	QC Check
8	2" Lag Bolts	
8	Flat Washers	
6 (2 Spare)	1 3/4" pan head screws	
5 (1 Spare)	7/8" Flat Faced Plugs	

QUALITY CONTROL CHECK PERFORMED BY: _____

ATTENTION  Do Not Assemble with Power Tools
--

ASSEMBLY INSTRUCTIONS:

- 1) **LOOSELY** ATTACH THE STRETCHERS TO BOTH LEGS USING THE HOLES IN EACH LEG WITH **8 - 2" LAG BOLTS**. MAKE CERTAIN THE COUNTERSUNK (WIDER END OF HOLE) SIDE OF EACH LEG IS FACING OUT (*FIGURE 1*).
- 2) TIGHTEN THE LAGS HOLDING THE STRETCHERS IN PLACE.
- 3) SET THE TABLE TOP UPON THE UPRIGHT BASE. MAKE CERTAIN TO ALIGN THE FLATNER STRAPS UNDER THE TABLE TOP WITH THE CENTER NOTCHES IN THE LEGS.
- 4) ALIGN THE PILOT HOLES IN THE CENTER SLAT OF THE EXTENSION SLIDES WITH THE HOLES IN THE SLIDE SUPPORT ATTACHED TO THE LEGS.
- 5) USE **4 - 1 3/4" PAN HEAD SCREWS** TO ATTACH THE BASE TO THE TABLE TOP (*FIGURE 2*).
- 6) PRESS PLUGS INTO PLACE OVER THE STRETCHER LAG BOLTS. IF PLUGS CAN NOT BE SECURED BY HAND, USE A RUBBER Mallet OR FOLD A SOFT CLOTH OVER THE PLUG AND **GENTLY** TAP INTO PLACE WITH A HAMMER.

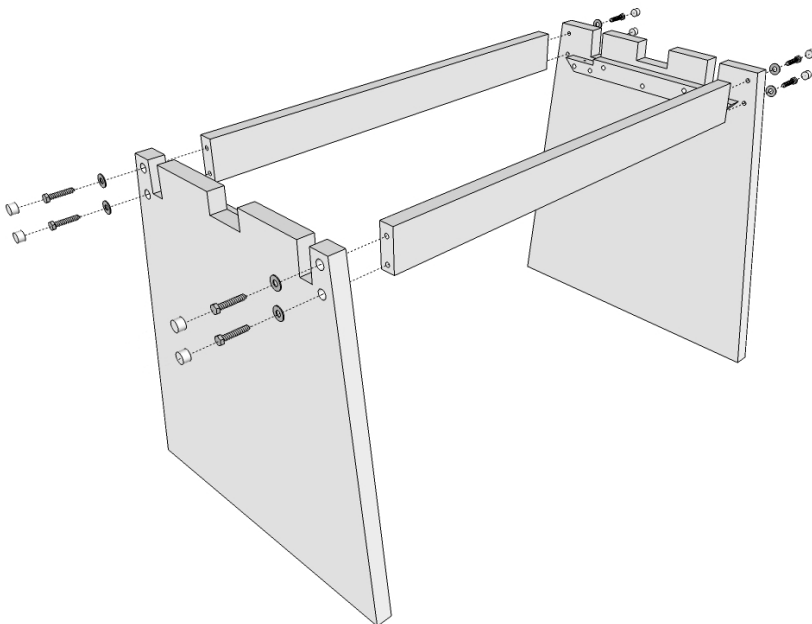

FIGURE 1

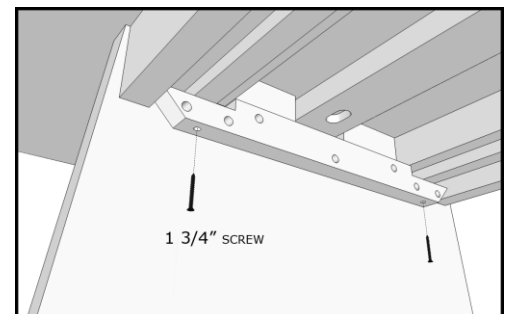

FIGURE 2