



SWEET LYNDON ACCENT TABLE ASSEMBLY

Base Part Location and Verification

Location	Quantity	Description	QC Check
Base Box	3	Hairpin Legs	

Hardware List and Verification

Quantity	Description	QC Check
12	3/4" button-head screws	

QUALITY CONTROL CHECK PERFORMED BY: _____

ATTENTION  **Do Not Assemble with Power Tools**

ASSEMBLY INSTRUCTIONS:

- 1) TURN THE TABLE UPSIDE DOWN AND PLACE ON A SOFT, NON-ABRASIVE SURFACE.
- 2) ATTACH THE HAIRPIN LEGS BY ALIGNING THE HOLES IN THE LEG BASE PLATES WITH THE PRE-DRILLED HOLES IN THE TABLE (*SEE FIGURE 1*).
- 3) USE 12 - 3/4" **BUTTON-HEAD SCREWS** TO **LOOSELY** SCREW THE BASE PLATES TO THE TOP (*SEE FIGURE 2*).
- 4) FINISH THIGHTENING ALL SCREWS INTO PLACE.

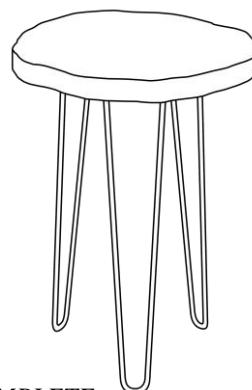
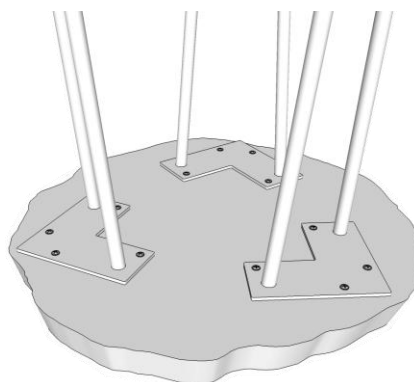
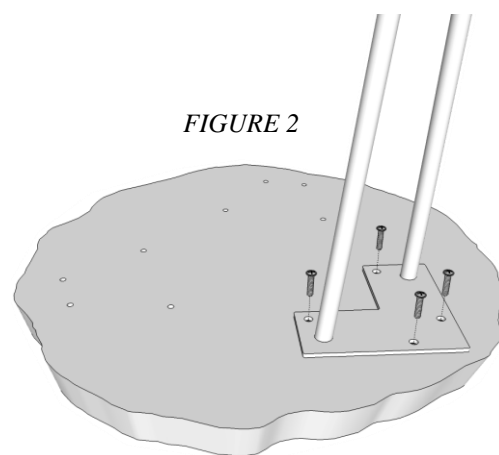
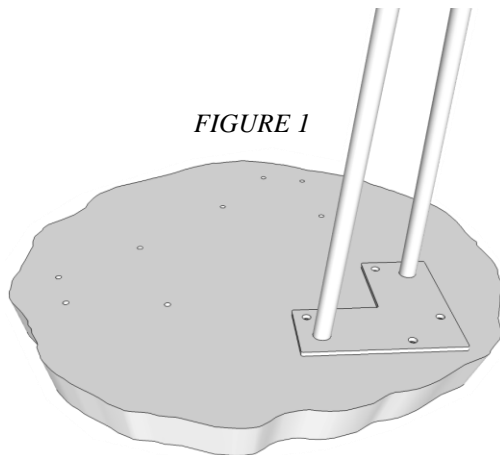

ASSEMBLY COMPLETE