



MISSION OCCASIONAL TABLE ASSEMBLY

Base Part Location and Verification

Location	Quantity	Description	QC Check
Base Box	2	Leg Assemblies	

Hardware List and Verification

Quantity	Description	QC Check
4	2 1/2" Lag Bolts	
4	Flat Washers	
16	1 1/4" Screws	

QUALITY CONTROL CHECK PERFORMED BY: _____

ATTENTION **Do Not Assemble with Power Tools**

ASSEMBLY INSTRUCTIONS:

- 1) TURN THE TABLE UPSIDE DOWN AND PLACE ON A SOFT, NON-ABRASIVE SURFACE.
- 2) PLACE THE NOTCHES IN THE LEG ASSEMBLIES AGAINST THE CORNER BLOCKS THAT PROTRUDE FROM THE SKIRT BOARDS ATTACHED TO THE TABLE (SEE *FIGURE 1*).
- 3) ATTACH THE CORNER BLOCKS TO THE NOTCHES IN THE LEG ASSEMBLIES WITH **8 - 1 1/4" SCREWS** (SEE *FIGURE 2*).
- 4) **LOOSELY** ATTACH THE LEG ASSEMBLIES TO THE CORNER BLOCKS USING THE **4 - 2 1/2" LAG BOLTS** (SEE *FIGURE 2*). TIGHTEN THE LAG BOLTS UNTIL THE LEG ASSEMBLIES ARE PULLED EVENLY INTO THE SIDE SKIRTS.
- 5) ATTACH THE LEG ASSEMBLIES TO THE BOTTOM OF THE TABLE TOP THROUGH THE POCKET HOLES USING THE OTHER **8 - 1 1/4" SCREWS** (SEE *FIGURE 1*).
- 6) CHECK ALL SCREWS AND BOLTS TO MAKE SURE THAT THEY ARE TIGHT AND SECURE.
- 7) CAREFULLY TURN TABLE UPRIGHT. ADJUST LEVELERS AS NEEDED.

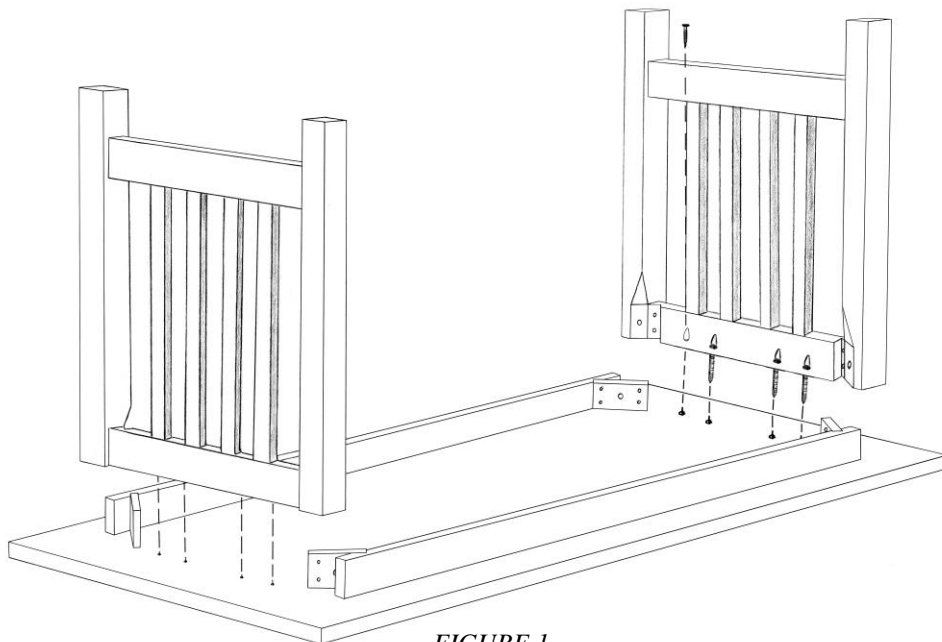

FIGURE 1

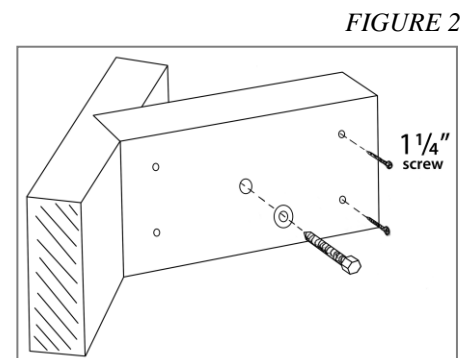

FIGURE 2